



TOOLS & INSTRUMENTS Co.

New Generation Technology Portable Digital Hardness Tester - ITI-130

Fully Automatic
Flexible, Rigid And Rapid The
Most Ability
The Least Restriction
Monolith, Yellow Parts

ITI-130

This device is built after two decades research and experience and disappears more limitations of conventional leeb devices and has developed portable hardness tester power range .

This device has new ability by electromagnetic shooting and infrared velocity measurement and eliminates mechanical parts.

Applications:

- Hardness testing of raw material
- Hardness testing of heavy and light pieces
- Hardness testing of metal pipes and CNG tanks N.D.T Testing
- Hardness testing of welding joints
- Hardness testing at production process
- Hardness testing of building structures and fuel pipes

Properties:

- Hardness test without complex setting
- Capability of testing more Alloys
- Showing hardness result on HLD-HRC-HRB-HB-HV-HSC
- Memory for 3000(approx.)test and USB port transferring
- Calibration by standard block and user
- Software user calibration
- Small and light weight with Poly Carbonate rigid case

Technical Specification:

Measuring Direction	360°
Display	LCD
Data Memory	500 Readings Approx.
Battery Pack	800^ 1600 mA ^H Li-ion 3.7V
Battery Charger	USB type
Continuous working period	3000-4000 Test Approx.
Communication Interface	USB1





Monolith Operation



Probe Separating ability

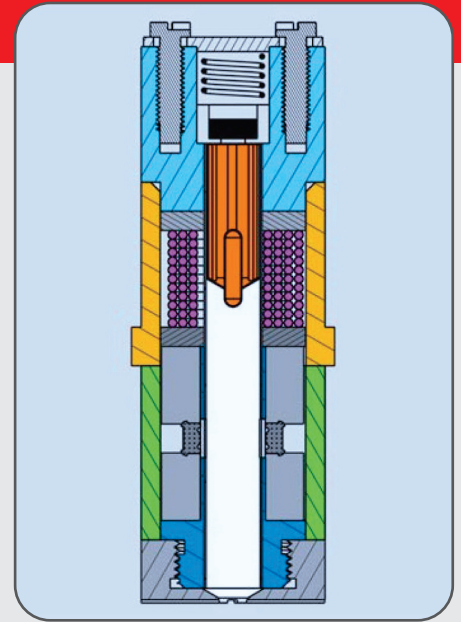

ITI-130 probe

Indenter 1.5 gr	Indenter 2.5 gr	Properties
H 30mm* x W 60mm* x L 170 mm		Dimension
+4 HLD (0.5% at 800 HLD)		Measurement Accuracy
Li-Polymer 1Ah 3.7V 5000 test by full charge		Battery & Consumption
+1 HLD Resolution		
200 grm*		Weight
15mm (Flat)	22mm (Flat)	Mini work Piece Thickness
5mm (pipe)	15mm (Pipe)	Mini work Piece Weight
Mini Thickness with Support		0.5mm

Low Alloy Steel	200-900 Leeb	80-647 Brinell 80-940 Vickers 41-99.5 Rockwell B 0-68.0 Rockwell C
High Alloy Steel	300-840 Leeb	80-898 Vickers 20.4-67.1 Rockwell C
Cast Iron	360-650 Leeb	93-334 Brinell
GGG	400-658 Leeb	25-198 Brinell
Brass	200-550 Leeb	40-173 Brinell
Copper	200-690 Leeb	45-315 Brinell

Compare Table:

	Conventional Leeb	ITI-130
Test Speed	Few Seconds	Sub Second
Work Piece Weight	1000 grm Mini.	200 grm Mini.
Work Piece Thickness	30 mm Mini.	15 grm Mini. (4mm)* Pipe Form
Prob Dimensions	More Bigger	15*45mm
Operation	Handy	Automatic
Indenter Durability	Approx 3000 tests	1 Lakh Tests Approx.
Error in Magnetic Piece	Yes	No
User Calibration	No	Yes
Battery Charging Time	4-5hrs	30 mini to 1 hrs.



Accessories:

- Standard reference block
- Battery charger
- convex and concave Heads and cleaning brush
- Hand bag
- Manuals
- Equation table (ASTM - A956)
- Software CD
- Calibration Certificate

Technical Specifications & Designs are subject to change without any prior notice

India TOOLS & INSTRUMENTS Co.

12/18, Tawa Lane, P. B. No. 3264, Mumbai - 400 003 • Phone : 2342 8862, • Mobile : 98193 45050
E-mail : ojus_itico@hotmail.com • visit us at : www.indiatool.net

New Generation Technology

Portable Digital Hardness Tester - ITI-130

Fully Automatic
Flexible, Rigid And Rapid The
Most Ability
The Least Restriction
Monolith, Yellow Parts



ITI-130

This device is built after two decades research and experience and disappears more limitations of conventional leeb devices and has developed portable hardness tester power range .

This device has new ability by electromagnetic shooting and infrared velocity measurement and eliminates mechanical parts.

Applications:

- Hardness testing of raw material
- Hardness testing of heavy and light pieces
- Hardness testing of metal pipes and CNG tanks N.D.T Testing
- Hardness testing of welding joints
- Hardness testing at production process
- Hardness testing of building structures and fuel pipes

Properties:

- Hardness test without complex setting
- Capability of testing more Alloys
- Showing hardness result on HLD-HRC-HRB-HB-HV-HSC
- Memory for 3000(approx.)test and USB port transferring
- Calibration by standard block and user
- Software user calibration
- Small and light weight with Poly Carbonate rigid case

Technical Specification:

Measuring Direction	360°
Display	LCD
Data Memory	500 Readings Approx.
Battery Pack	800^ 1600 mA ^H Li-ion 3.7V
Battery Charger	USB type
Continuous working period	3000-4000 Test Approx.
Communication Interface	USB1





Monolith Operation



Probe Separating ability

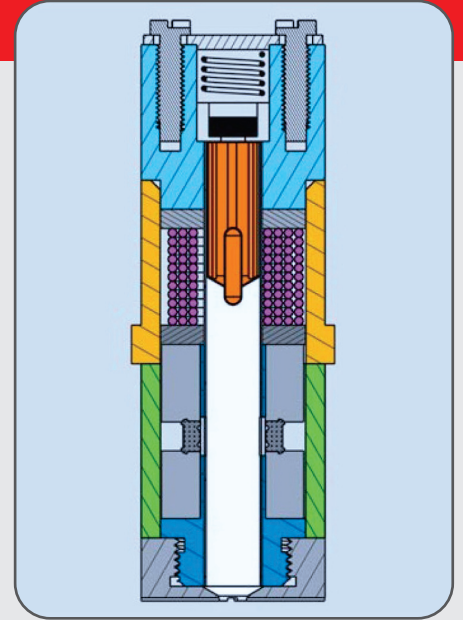

ITI-130 probe

Indenter 1.5 gr	Indenter 2.5 gr	Properties
H 30mm* x W 60mm* x L 170 mm		Dimension
+4 HLD (0.5% at 800 HLD)		Measurement Accuracy
Li-Polymer 1Ah 3.7 V 5000 test by full charge		Battery & Consumption
+1 HLD Resolution		
200 grm*		Weight
15mm (Flat)	22mm (Flat)	Mini work Piece Thickness
5mm (pipe)	15mm (Pipe)	Mini work Piece Weight
Mini Thickness with Support		0.5mm

Low Alloy Steel	200-900 Leeb	80-647 Brinell 80-940 Vickers 41-99.5 Rockwell B 0-68.0 Rockwell C
High Alloy Steel	300-840 Leeb	80-898 Vickers 20.4-67.1 Rockwell C
Cast Iron	360-650 Leeb	93-334 Brinell
GGG	400-658 Leeb	25-198 Brinell
Brass	200-550 Leeb	40-173 Brinell
Copper	200-690 Leeb	45-315 Brinell

Compare Table:

	Conventional Leeb	ITI-130
Test Speed	Few Seconds	Sub Second
Work Piece Weight	1000 grm Mini.	200 grm Mini.
Work Piece Thickness	30 mm Mini.	15 grm Mini. (4mm)* Pipe Form
Prob Dimensions	More Bigger	15*45mm
Operation	Handy	Automatic
Indenter Durability	Approx 3000 tests	1 Lakh Tests Approx.
Error in Magnetic Piece	Yes	No
User Calibration	No	Yes
Battery Charging Time	4-5hrs	30 mini to 1 hrs.



Accessories:

- Standard reference block
- Battery charger
- convex and concave Heads and cleaning brush
- Hand bag
- Manuals
- Equation table (ASTM - A956)
- Software CD
- Calibration Certificate

Technical Specifications & Designs are subject to change without any prior notice

Dealers Name & Address: